

bushing hole diameter 9,8 - 10 mm
Lagerbüchse, Bohrungsdurchmesser 9,8 - 10 mm

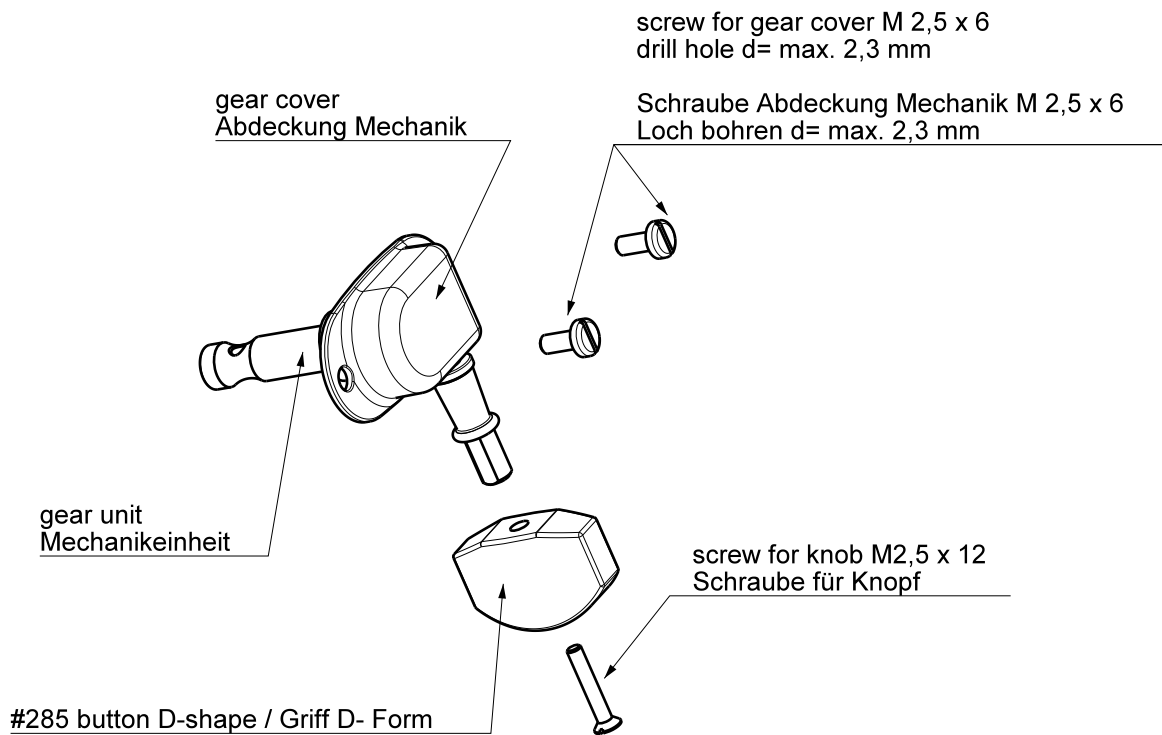

Miller

Mechanik Modell Jazz / tuner model Jazz